

WARNING: Do Not Operate Before Reading Manual

KDH Series OPERATOR'S MANUAL

Models

KDH-130 KDH-150



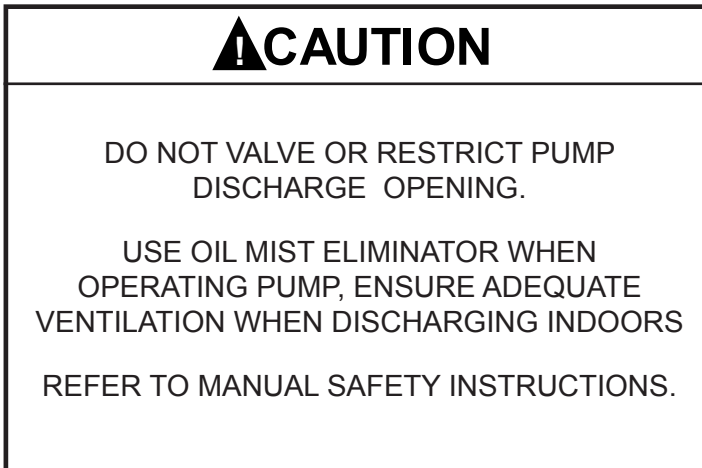

NOTICE

The above safety instruction tags were permanently affixed to your pump prior to shipment.
Do not remove, paint over or obscure in any manner.

Failure to heed these warnings could result in serious bodily injury
to the personnel operating and maintaining this equipment.

SAFETY PRECAUTIONS FOR ROTARY PISTON PUMPS

Please read the following safety information on this page before operating your vacuum pump.

- Do not operate the pump without the belt guard properly attached. Disconnect the pump motor from the electrical supply at the main disconnect before removing the belt guard. Replace the belt guard before reconnecting the power supply to the pump motor. Operating the pump without the belt guard properly installed exposes personnel in the vicinity of the pump to risk from rotating drive components.
- Do not operate the pump with oxygen-enriched gas (greater than 21% by volume) in the suction line, unless the pump has been prepared with an inert fluid suitable for the application and equipped with seal and start/stop purge system. Pumping oxygen-enriched gases with mineral oil or other non-inert fluids and without proper purges can cause fire or explosion in the pump, resulting in damage or serious bodily injury.
- Take precautions to avoid prolonged or excessive exposure to oil mist or process materials emanating from the discharge of the pump.
- Do not allow the pump to discharge into a closed, or inadequately ventilated room. Where process vapor contains environmentally unfriendly chemical vapor, pump discharge must be connected to the properly sized scrubber system to neutralize the harmful chemicals prior to the discharge to the atmosphere. Laws and ordinances may pertain to your local area regarding discharge of oil mist, oil vapor, chemical vapor to atmosphere. Check local laws and ordinances prior to operation of the pump with discharge to outside atmosphere.
- Do not restrict the pump discharge in any way, or place valves in the discharge line. The vacuum pump is a compressor and will generate high pressures without stalling the motor when operated at low suction pressures. Excessive pressure could cause damage or serious bodily injury.
- Disconnect the pump motor from the electrical supply at the main disconnect before disassembling or servicing the pump. Make sure pump is completely reassembled, the belt guard is properly installed, and that all fill and drain valves are installed and closed before reconnecting the power supply. Accidental starting or operation of the pump while maintenance is in progress could cause damage or serious bodily injury.
- Lift pump only by the lifting lugs supplied with the pump. DO NOT lift equipment attached to pump by the pump lifting lugs.
- Do not touch hot surfaces on the pump. In normal operation at low pressures, surface temperatures will not normally exceed 180° F (82° C). Prolonged operation at 200 Torr (267 mbar a) may cause surface temperatures as high as 220° F (104° C)

TABLE OF CONTENTS

	PAGE
INTRODUCTION	4
Replacing KDH-130 with KDH 130B	4
DESCRIPTION	4
Operating Mechanism	4
Inlet & Outlet Valves	5
Sealing and Lubrication	5
Sealing Oils	5
Operating Cycle	5
Gas Ballast	5
Dynamically Balanced Pump	6
INSTALLATION	6
Mounting the Pump	6
Connecting Cooling Water	6
Vacuum Piping	6
Oil Separator Piping	6
Electrical Connections	6
Prestart Checks	7
OPERATION	7
Starting the pump	7
Stopping the pump	7
Changing the Oil	7
Gas Ballast	8
Oil Separator	8
SOLENOID VALVES	8
General Instructions	8
Electrical Connections	8
Overheating of Coils	9
Sticking and Jamming	9
Wet Coils	9
Coil Replacement	9
Noise	9
TROUBLESHOOTING	9
General	9
Isolating Troubles	9
Checking Process Equipment	9
Leak Checking Techniques	10
Pump Test	10
Pump Leaks	11
Solenoid Valve	11
Discharge Valves	11
Mechanical Shaft Seal	12
Stalling	12
MAINTENANCE	13
General	13
Pump Periodic Maintenance	13
Cleaning contaminated Process Equipment	13
OVERHAUL	13
General	13
Disassembly	14
Assembly	14
REPLACEMENT PARTS	15
Spare Parts	15
Ordering Parts	15
WARRANTY	18

INTRODUCTION

GENERAL

This manual applies to KDH-130, and KDH-150 pumps built from 1974 to date. Earlier models may differ.

The KDH-130 was replaced by the KDH-130B (and by the KDH-131 for radiator filling applications) in November 1987. Serial numbers between 871080 and on are the new "B" model. The differences between the KDH-130 and the KDH-130B are:

1. The cylinder casting design is changed, and new water jacket plates are fitted to the KDH-130B.
2. The KDH-130B is five inches shorter than the previous model due to a more compact shaft support structure.

REPLACING KDH-130 WITH KDH-130B

If there is no fixed vacuum manifold and the suction flange position can be changed, use the bolt down holes provided in the bottom plate which line up with the bolt holes in the existing base. The whole pump will move 2-7/8 inches toward the drive.

If the vacuum manifold is fixed and the base cannot be moved, bolt the pump down in line with the manifolding. The belt guard and motor base must be moved 2-7/8 inches toward the center of the base as follows.

Modify the belt guard mounting brackets by bending them or cutting off and welding short angle iron brackets with bolt holes. New matching bolt holes must be provided in the base. Welding hex nuts under the base is recommended.

The new positions of mounting holes for the motor base may interfere with stiffening ribs under the base. Welding the motor base in position is recommended.

SPECIFICATIONS		
	KDH-130	KDH-150
Normal Pump Speed (RPM)	546	673
Displacement (CFM)	134	165
Motor Speed (RPM)	1750	1750
Motor H P	5	7.5
Oil Capacity (US gal.)	6	6
Cooling water Rqd. (US gpm)	0.75	0.75
Net Weight, Complete (lbs.)	755	790

DESCRIPTION

OPERATING MECHANISM

Cross sectional views have been included in the back of this manual to assist in repairing the pump and identifying the parts. It may be helpful to refer to this illustration and to Figure 1 in order to better understand the following paragraphs.

The KDH series is water-cooled, single stage, and of the cam and piston type. In order to balance the moving parts, the pump cylinder is internally divided into two sections having a common inlet and discharge.

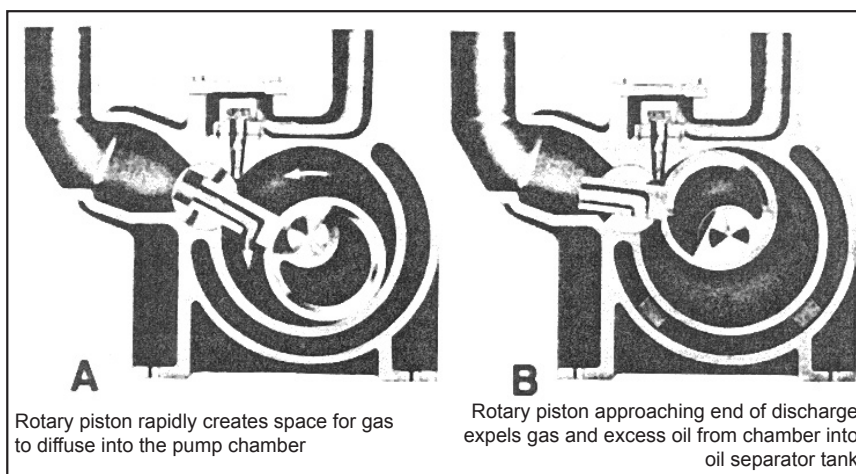

Figure 1. Operating Cycle of KDH Series Single Stage Pumps

Within each section is a piston which is driven by a cam. The cams are mounted 180 degrees apart on a single shaft so that the centrifugal forces of the moving pistons will oppose one another. The shaft passes through the center wall separating the two pump sections and is supported in bearings in the heads at each end of the cylinder. The open head, through which the shaft extends, has a shaft seal to prevent air leakage into the pump, and an outboard bearing to handle belt pull.

Each piston has an integral hollow extension (called a slide) which extends through a slidepin. One side of the slide contains diagonal slots; as the slide passes back and forth through the slide pin, these slots are covered and uncovered to form an inlet valve. Outlet valves are mounted over the discharge port on top of the cylinder. All working parts are precisely machined to suitable clearances for high vacuum requirements.

INLET AND OUTLET VALVES

The covering and uncovering of the slots in the piston slide by the slide pin constitutes a mechanical inlet valve. Air or gas is admitted through these slots from the high vacuum side of the slide pin into the space between the piston and the cylinder at certain parts of the cycle. As there is no spring loading, no pressure difference is required to operate this valve. The outlet or discharge valve is opened automatically by the compression of air or gas in the pump against atmospheric pressure, plus a light spring pressure.

SEALING AND LUBRICATION

Since the success of the pump depends on its being sealed and lubricated, an oil separator tank is mounted above the pump just to one side of the valve chamber. From here on, the word oil will be used to refer to the liquid which seals and lubricates the inside surfaces of the pump. Oil is generally used except for special conditions as noted under Sealing Oils in this section.

SEALING OILS

AX oil is recommended for all applications compatible with mineral oils. Other liquids may be suitable for special conditions.

The sealing oil should be free from gases or moisture. Otherwise, the vapors will be pulled out of the oil and will prevent obtaining low absolute pressure. See Gas Ballast section, page 8.

OPERATING CYCLE

The operating cycle of the Kinney pump is shown by cutaway views in Figure 1. In view A the piston moving in the direction of the arrow is rapidly creating more space into which some of the gas is admitted through the inlet port; at the same time the compression of the gas previously trapped is taking place on the opposite side of the piston. In view B the piston has almost reached the end of the discharge, expelling all air or gas and surplus sealing oil through the outlet valve (poppet type) and nozzle into the separator tank where the oil is retained and the air or Gas admitted to the full space created is trapped and then expelled in the manner previously described.

Throughout the operating cycle, the cylindrical part of the piston is always close to, but not touching the bore of the pump cylinder. In this small gap, an effective oil seal is built up ahead of the piston, which in addition to the film of oil between the ends of the piston and face of the heads, as well as the slide pin clearances, prevents leakage from the compression or atmospheric side to the vacuum side. Re-expansion is reduced to a minimum, a condition essential to low ultimate pressure and high pumping speed over a large pressure range.

GAS BALLAST

Gas ballasting may be used to reduce the number of oil changes caused by contamination of oil by condensable vapors or gases. Vapors or gasses such as water vapor, acetone, alcohol, kerosene and others, may be drawn over from the system and condensed in the pump. The gas ballast line admits atmospheric air to the compression space during part of the compression cycle to prevent such condensation. See OPERATION for more details.

DYNAMICALLY BALANCED PUMP

The term “dynamically balanced” applies to pumps which have been specifically balanced to reduce vibration. The KDH series are dynamically balanced by having each cam a different weight and adding counterweight to the pump sheave. The heavier cam is installed on the open head or drive shaft end of the pump. When reassembling a pump or ordering parts, be careful to distinguish between the heavy or open head cam and the light or closed head cam. Always use the correct counterweighted sheave.

INSTALLATION

WARNING: Disconnect the pump from source electrical power prior to making repairs or adjustments to any electrical components of the unit.

MOUNTING THE PUMP

The pump unit should be mounted on a suitable rigid foundation and securely fastened down.

Connecting the Cooling Water

CAUTION: Do not allow the cooling water to freeze.

The pump is water jacketed. A small water line, with control valve, should be connected to the water inlet on the suction side of the pump. The water outlet is on top of the cylinder near the open head end, and should preferably be piped into an open funnel so that the operator can tell if water flow and temperature are satisfactory. Control the water flow so as to have the discharge water between 95° and 110°F when the incoming water is between 50° and 70°F. Where the water is extremely cold, control the flow so that the pump runs just warm to the touch.

VACUUM PIPING

For best results it is important that the inlet or vacuum pipe line to the pump be as large and short as possible. It should not be smaller than the inlet port to the pump.

The best piping for the vacuum side of the pump is made up with flanges using neoprene gaskets or O-rings. Flanges may be welded or threaded to the pipe. If threaded connections are used, thread sealing compound or PTFE tape should be used to seal threads up to one inch in diameter. Heavy sealing compound such as Tite Seal may be used on threads over one inch in diameter.

OIL SEPARATOR PIPING

The discharge from the oil separator may be piped out of doors or any place convenient. In any case, be sure that the discharge line does not leave the separator vertically for any great length. This would permit the vapors to condense in the pipe, drip back into the tank and contaminate the oil.

Come out to the tank with a horizontal run to a drop-out tee, and then go vertically up if necessary. Equip the tee with a drain cock to draw off condensate from time to time as required. Oil mist eliminators (OME) are available to take the place of the piping. In addition OME's reclaim oil lost in the discharge if not contaminated by water or process vapors.

Fill the oil separator with sealing oil through the filling elbow on the side of the oil separator. Refer to the SPECIFICATIONS section for the quantity and type of oil required.

ELECTRICAL CONNECTIONS

Connect the power supply to the motor. Refer to the Solenoid Valve Section for information on for the solenoid valves.

PRESTART CHECKS

1. Be sure that the suction lines are absolutely free of foreign matter and perfectly tight. Use an inlet protection screen or drop out trap on new installations or where large welded piping is employed.
2. Make sure that the pump discharge is not obstructed
3. Check that the cooling water is available and connected to the pump.
4. Check the oil level and adjust if necessary. Proper oil level is about 1/4 inch above the center of the sight glass on the side of the separator.
5. Ensure that the oil solenoid valve is wired correctly.
6. Check for correct rotation of the pump. Facing the drive end of the shaft the suction is on the left and rotation should be counter-clockwise. If the rotation is not correct reverse any two wires at the motor terminals.

OPERATION

WARNINGS:

- The beltguard must be properly secured to the pump at all times while the pump is running.
- When operating the pump in an enclosed area it is necessary, for health reasons, that the pump discharge should be filtered or piped to open air.
- Do not block or restrict the flow of gas from the pump discharge. Back pressure within the pump could cause severe damage.
- Each pump is fully tested at the factory and the rated blank-off pressure should be attained once the pump is correctly installed. Note that on applications requiring continuous operation at high pressures (above 50 Torr), it is recommended that the pump be operated for 8 to 24 hours with pump inlet at one Torr or less. This allows proper wear-in and seating of the discharge valves.

STARTING THE PUMP

1. Avoid starting the pump with the suction line under vacuum
2. Close the vent valve if one is used.
3. Start the pump.
4. Turn on the cooling water and adjust the flow as shown in the specifications.
5. Adjust the gas ballast as required.

STOPPING THE PUMP

1. Close the isolation valve in the suction line, if one is installed.
2. Vent the pump to atmosphere through a vent valve or the gas ballast valve.
3. Stop the pump.
4. Shut off the cooling water.

CHANGING THE OIL

The pump temperature should be near normal operating temperature (140°F) to drain the oil more easily. Run the pump for half a minute with the suction open to atmosphere (e.g., with a gauge connection open). Place a container under the drain valve in the oil separator and open the valve until the oil is removed from the pump.

If the oil is being drained due to oil contamination it is advisable to drain the oil from the discharge valve as well. This well or trough can be reached by removing the valve chamber cover plate on the top of the pump.

When the oil has drained from the pump, close the drain valve and fill the pump with the quantity and type of oil shown in the specifications. The oil level will show above the center of the sightglass until oil is distributed throughout the pump.

GAS BALLAST

The gas ballast valve is a manual valve located on top of the pump between the suction flange and the drive end. A pipe connects it to both ends of the pump.

Oil sealed mechanical vacuum pumps can become contaminated by vapors (commonly water or solvents) which have condensed and mixed with the oil. The contaminant vaporizes in the low pressure suction space and prevents gas from being drawn into the pump which dramatically impairs pump performance.

The gas ballast valve admits atmospheric air into the pumping chambers after they have closed. This reduces low pressure pumping speed but increases gas temperatures, preventing vapors from condensing. Opening the gas ballast valve can help avoid vapor contamination or rectify moderate vapor contamination. Heavy contamination may require changing the oil.

To remove vapor contaminants from the oil, isolate the pump from the system, fully open the gas ballast valve and run the pump overnight. If this is not possible, open the gas ballast valve during periods when this will not affect the process, such as during loading and unloading.

To estimate the time running with gas ballast open required to clean the oil, read the blank-off pressure with the gas ballast valve closed then run for 5 or 10 minutes with the valve fully open. Close the gas ballast valve and read the blank-off pressure again. Use the observed rate of change to estimate the amount of time to achieve the desired blank off pressure.

It may be possible to run the pump continuously with the gas ballast valve partially open. Open the valve until the blank-off pressure is slightly below the highest pressure level at which the process can be performed. This is particularly useful in humid climates

OIL SEPARATOR

The oil separator acts as a baffle to prevent large oil droplets from being expelled from the pump and is a reservoir for oil; a sightglass indicates the oil level.

Water may condense in the separator tank and collect in the bottom. The oil feed line, via the solenoid valve, to the pump protrudes above the bottom of the tank to avoid drawing water into the pump. This water may be drained manually through the oil drain valve.

Where large quantities of water condense regularly, an automatic drain valve may be fitted. Consult the factory for recommendations on how this may be fitted.

The oil separator may emit some oil smoke when the pump is operated at high pressure. This can be avoided by fitting an oil mist eliminator to the top of the separator tank, and piping the discharge from the oil mist eliminator.

SOLENOID VALVES

GENERAL

Valve bodies should be connected in the pipe line with the pressure drop across the valve in such a direction as to hold the valve disk firmly on its seat when the valve is closed. The arrow in the valve body indicates the proper direction of pressure drop.

ELECTRICAL CONNECTIONS

Check the operating voltage of the solenoid valve and motor from the component nameplates. If the solenoid valve is dual voltage make sure it is wired in accordance with the diagram on the coil.

OVERHEATING OF COILS

Coils are designed to operate with about 50°F temperature rise. Since coils are furnished to hold the valve open they should not exceed this temperature in normal operation. Hot smell or smoke calls for investigation. First check for valve not opening due to low voltage. Failure of the valve to open when energized will cause overheating.

STICKING AND JAMMING

Foreign matter may cause the valve to stick, jam or leak. Any solenoid valve should be cleaned periodically. Solenoid valves should be cleaned when the oil is changed due to contamination by foreign matter.

WET COILS

Valves are designed for use in comparatively dry locations and in temperatures up to 115°F. Weatherproof valves are available for wet locations and have threaded holes for the use of conduit.

COIL REPLACEMENT

Should a coil fail for any reason or if it is desired to change to a different voltage, this is easily done without disturbing the piping. Take off the coil retaining clips and remove the coil.

NOISE

There is always a slight hum when the solenoid is working, like that of a small transformer. A rattling noise when the coil first receives current may be due to dirt in the core space, which should be cleaned out. When the solenoid opens properly a slight click may be heard as the core hits the plug at the top of the core tube. If surrounding noise prevents hearing this, the fingers may be placed on the nut at the top where a slight bump can be felt.

TROUBLESHOOTING

GENERAL

If the system is not operating satisfactorily, a few simple checks should be made before taking the pump apart. The most common troubles causing poor vacuum air leaks into the system and contaminated sealing oil.

Two types of vacuum gauges are used for testing vacuum equipment; total pressure reading types such as the thermocouple gauge and the partial pressure McLeod gauge. The McLeod gauge indicates the partial pressure of permanent gases. It is most useful in confirming the absence or presence of real leaks. The thermocouple gauge is preferable for leak checking and indicating the degree of contamination.

ISOLATING TROUBLES

First, isolate the trouble to either the process equipment or the vacuum pump by performing the following test:

Close the high vacuum valve or isolate the pumping unit from the process equipment by means of a blank-off plate. Start the vacuum pump. Read the lowest pressure attainable at the pump inlet with a McLeod gauge. This should be done about 10% lower than the operating pressure needed. If the blank-off pressure is acceptable, the pump is functioning properly. The process equipment is at fault. Proceed as directed in Checking Process Equipment. If the blank-off pressure is too high, indicating that the pump is at fault, proceed as directed in Pump Test.

NOTE: A gauge reading differential of +/- 10% is normally acceptable.

CHECKING PROCESS EQUIPMENT

If the blank-off test shows that the vacuum pump is functioning properly but that the process equipment is faulty, the trouble can be isolated further by applying the following procedures:

Pump down each segment of the process equipment individually, starting at the segment closest to the vacuum pump.

Check the lowest pressure attainable when each segment is added. If the pressure is close to that obtained previously, add the next segment. If the pressure is not, leak test the last segment.

When leak checking process chambers, start at the air and gas inlet valves, doors, sight ports, electrical and mechanical feed-throughs, gauge tube fittings and any other penetrations into the vacuum portion of the process equipment. Check especially gasketed and O-ring connections. After a suspected leak has been found, cover it with plastic sealing compound such as Apiezon-Q, and check the equipment performance before sealing the leak permanently. Thus, all permanent repairs can be made at the same time.

LEAK CHECKING TECHNIQUES

If a leak detector is not available, use the following methods to locate leaks:

Cover the suspected leaks with a low vapor pressure sealing compound such as Apiezon Q, or Duraseal. Do this while pumping on the equipment and monitoring the pressure. A sudden decrease in pressure indicates that a leak has been covered. Repair leaks permanently as previously directed.

If the leak is large, causing pressures in the Torr range, use a fast acting thermocouple gauge in conjunction with a probing medium such as freon or helium. Position the vacuum gauge head downstream from the suspected leak and pump. When the pressure has been reduced so that the gauge may be used, apply probing medium to suspected leak areas. If the probing fluid is directed at the leak or an area close to it, a sudden change in pressure will occur. Cover the suspected leak with plastic sealing compound and continue leak checking until desired pressure is obtained. Repair leaks.

If leak checking fails, disassemble and remake all demountable joints and connections using new gaskets or vacuum sealing compound such as Loctite 515.

PUMP TEST

To check the condition of the pump, measure the blank-off pressure as directed below using a McLeod gauge. If possible, also read the blank-off pressure with a thermistor or thermocouple gauge to check the condition of the pump oil.

To read the blank-off pressure:

1. Close off the pump inlet by means of a high vacuum valve or blank-off plate.
2. Connect a vacuum gauge to the pump side of valve or blank-off plate. Position it so that it will not become flooded by pump oil, preferably in the blank-off plate facing into the pump section.
3. Operate the pump for a short period, about 15 minutes, until the lowest pressure is reached. Note the reading obtained.

The reading obtained should be between the pump's specification blank-off pressure (low end) and the pressure needed for the process (high end).

Average blank-off readings are 5 to 50 microns, McLeod, and 10 to 100 microns, thermocouple. The specification pressure is 10 microns, McLeod.

If the McLeod gauge reading is low and the thermocouple gauge reading is high, the pump oil is contaminated. Change the oil and recheck the pump blank-off pressure. (In some instances it is necessary to change the oil several times to flush all traces of contamination from the pump.) Note that if a thermocouple gauge is not available, and the pump oil has been in service for an appreciable period, it is best to change the pump oil several times to eliminate pump oil contamination as a possible cause of poor pump performance. After changing the oil, recheck the blank-off pressure.

If both the McLeod and thermocouple gauge readings are high, indication that the oil is not contaminated, the pump is leaking. Proceed as directed in Pump Leaks.

PUMP LEAKS

If the vacuum pump is suspected of leaking (after eliminating oil contamination as the cause of poor performance), use plastic sealing compound to seal over suspected areas, and check pump blank-off performance before making

permanent repairs with Loctite 515. If gasketed connections are suspected, remake the connections. (Plastic sealing compound may be used to make temporary gaskets; these should not be made too thickly since the material may be squeezed into the pump.)

Check carefully around the head to cylinder joints, securing bolts, oil lines, plugs, and generally any penetration into the vacuum pumping portion of the pump. Check the inlet connection for proper sealing. If this fails, check the shaft seal for mechanical defects, such as cracked carbon washer or hardened rubber components. Refer to the Overhaul section for details on disassembly and overhaul.

SOLENOID VALVE

If the pump has been operating for some time and the oil in the separator is cool while the pump is hot, check the solenoid valve for proper opening. This is explained under Noise in the Solenoid Valve section, page 9.

DISCHARGE VALVES

The KDH-130, and KDH-150 use 1-1/2 inch diameter discharge valves. The discharge valves are shown in Figure 2.

If the pump blank-off pressure is excessively high and the discharge valves are suspected as the cause, check the discharge valves as follows:

1. Drain all the oil from the valve chamber and nozzle by removing the pipe plug on either end of the valve chamber.
2. Remove the discharge valve cover and gasket.
3. Remove the valve deck securing screws and lift out the decks and valves.

Inspect the valves for damage or foreign material. Lift and snap the disc to check spring tension. Replace valves or parts as required. Note the order of disassemble so that parts can be replaced in the same order. When reassembling, do not use sealing compound at either the valve deck or the valve deck cover gaskets.

To reassemble the flat spring type 1-1/2 inch discharge valve, proceed as follows:

1. Combine the six individual

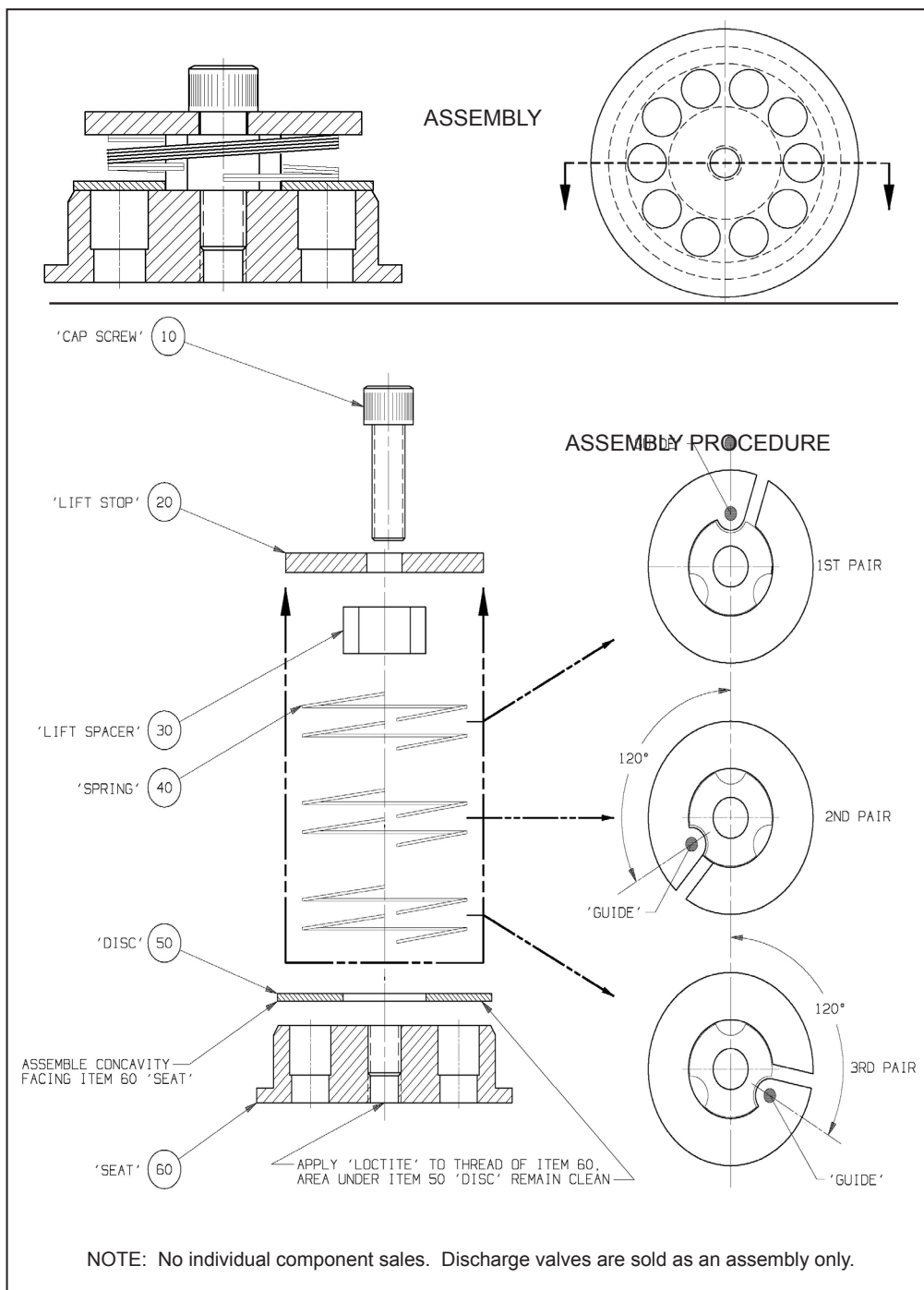

Figure 2. Discharge Valve

springs into three pairs, aligning the guide tabs in each pair.

2. Slide the first pair of springs on to the lift stop with the guide tab first. That is, with the guide tab retaining groove between each spring pair so that the springs are spaced equally around the valve.
3. Position the springs and lift stop over the seat and disc. Apply a small amount of Loctite AC on the threads of the hex socket capscrew. Secure the valve assembly together with the screw. Wipe any excess Loctite from the valve. With a seal-locking type screw, Loctite need not be used.
4. When returning the discharge valves to the pump, check that each disc is free to move properly.
5. After installing the valves in the pump, check that the valve assemblies cannot be turned, indicating that they are tightly in position.

MECHANICAL SHAFT SEAL

The shaft seal has a long, trouble-free life under normal conditions. However, it may be worn or scratched on the sealing faces by contaminated sealing and lubricating oil, or possibly by a lack of oil.

To inspect the seal, remove the belts from the pump sheave. Remove the pump sheave and drive key from the shaft. Remove shaft seal drain plug (underneath shaft seal housing, second from shaft extension) and drain the oil. Then, disconnect the tubing.

Remove the capscrews holding the shaft seal housing to the end of the open head and draw off the housing. This will leave the inner race of the roller bearing and part of the shaft seal on the shaft. The floating seat and sealing ring (see cross section view) should stay inside the housing when the housing is removed. Draw the rotating parts of the seal off the shaft; spring holder and snap ring may be left on if the open head is not being removed. Inspect the running face of sealing washer for dirt, scratches or grooves which might account for leaks through the seal. Look at the inside of bellows to see that it is not cracked or grooved as it prevents leakage along the shaft. Look inside the shaft seal housing at the face of floating seat to see that it is not grooved. To check sealing ring, it is necessary to remove outboard bearing cap and push the ring out of the hole. If this is done, check the roller bearing, roller assembly and the running face of the races. In reassembling, if floating seat and sealing ring are out, be sure and put the sealing ring on the floating seat and then coat the sealing ring with the oil. Push it into its hole in the shaft seal housing slowly and carefully so that the ring will not roll. A crease across the sealing ring, or a dent or scratch in the running face makes a direct leak through the seal. Even new seals may leak if installed carelessly. Slide the moving seal parts back on the shaft, in order removed, up to the spring holder and snap ring. Then clean the face of the flanges on the open head and then clean the shaft housing making it free of old sealing compound. Apply a thin coat of new sealing compound and install the housing. Re-install the roller bearing outer race, or roller assembly if removed, and pack with grease. Put the outboard bearing cap on and tighten. Reconnect the tubing, put the key back in the shaft, mount the pump sheave and put the belts back on.

NOTE: When replacing the shaft seal, the bearing and locknut should be replaced.

STALLING

Difficult pump starting may result from excessively low pump temperatures which can be caused by leaving the pump cooling water flow on when the pump is stopped, or by exposing the pump to low ambient temperatures. If this occurs, warm the pump to the minimum pump starting temperature of 50° F.

If the pump stalls at any time, it may be due to a loose belt, lack of lubrication, solenoid valve not opening, badly contaminated oil, or foreign matter in the pump. If the pump can be turned over by hand, check belt tension as noted under the OPERATION section. If stalling is due to lack of lubrication, the oil line has become plugged suddenly after operating for some time. Check the opening of the solenoid valves as previously described. If conditions do not improve, remove the oil seal lines and clean them, as they are probably plugged. If a check of the oils shows that it is not badly contaminated, there could be foreign matter in the pump. The oil can be changed, as covered under Changing the Oil, but if it is contaminated enough to stall the pump, the inside of the pump must be cleaned. Cleaning or inspecting the inside of the pump is a major operation, and is covered in the OVERHAUL section. The closed head end is easily checked by closing off the oil, disconnecting the tubing to that end, removing the capscrews and drawing off the head which permits drawing out the piston and slide pin. See OVERHAUL for disassembly of the open head end.

MAINTENANCE

GENERAL

Because of different operating conditions, and applications, a rigid maintenance schedule cannot be stipulated. Where possible, required maintenance is given on an operating hour basis. Where this is not possible, experience or poor performance will dictate the need for maintenance. A careful record of pump blank-off readings and process chamber pumpdown times should be kept to aid in maintaining and troubleshooting this unit.

Pump repair services are available at our factory in Springfield, MO, our Northeast Repair Center in the Boston, MA area and our West Coast Service Center in the Los Angeles, CA area. Call (800) 825-6937 for a location nearest you for more information.

PUMP PERIODIC MAINTENANCE

Check the oil level daily for the first week of operation, and weekly thereafter. The oil level should be about 1/4" above the midpoint on the sight gauge and changes when the pump is operating normally. At high pressures, or with a gas ballast flow, the oil level should be appreciably higher than it is when operating at low pressures, near blank-off. If there are no changes in the oil level, check for obstructed oil passages in all oil lines and solenoid valve.

Check the condition of the oil periodically by draining a small quantity of oil into a clean container and visually inspecting it for solid or liquid contaminants. Change the oil when contaminated.

There is no fixed interval for changing pump oil, since applications vary widely. This can be determined only by experience and/or by deterioration of pump performance.

CLEANING CONTAMINATED PROCESS EQUIPMENT

Process equipment contamination which may result in poor chamber pressures is often caused by condensable vapors such as water vapor and can readily be removed. An extremely long pumping cycle indicates severe contamination; a moderately longer than normal cycle indicates slight contamination. Operating experience is usually the best guide.

If the contamination is heavy, operate the pumping equipment on process equipment overnight. Open the vacuum pump gas ballast valve to prevent pump oil contamination.

If the contamination is slight, operate for a few hours with gas ballast. Application of gas ballast during processing will eliminate or reduce oil contamination.

If the process equipment is heavily contaminated, wipe down the chamber walls with cloths soaked in ethyl alcohol, acetone, or other solvent. When starting the pumping equipment, open the gas ballast valve to avoid pump oil contamination.

Note that the initial pumpdown cycle will be longer than usual due to the evaporation of the cleaning fluid. Once the working pressure is reached, subsequent pumpdown cycles should be normal.

OVERHAUL

GENERAL

Arrangements for repair service can be made with Tuthill Vacuum & Blower Systems to either repair pumps on site or return them to the manufacturer for repair. Call Tuthill Vacuum & Blower Systems at (800) 525-6937 for service locations or for the proper procedure to return a pump back to the factory for repair.

KDH-130B & 150 DISASSEMBLY (See pages 16 & 17)

1. Drain oil and water.

2. Remove oil and gas ballast lines.
3. Remove CE (closed end) cap and CE head.
4. With the cam and piston towards the bottom of the cylinder bore, remove the piston and slide pin.
5. Remove clamping plate, locknut and shaft seal housing.
6. Knockout bearing, backup ring and seal seat from shaft seal housing.
7. Remove seal assembly and retaining ring from shaft.
8. Remove OE (opened end) head. Do not remove piston and slide pin at this time.
9. Remove CE head cam by using pullers and eyebolts on cam or tapping shaft through cam being careful not to damage the end of the shaft.
10. With the cam and piston towards the bottom of the cylinder bore, remove the piston and slide pin on OE head side.
11. Remove slide pin from piston.
12. Remove shaft and cam.
13. Remove cam from shaft if replacing one or the other.
14. Remove valve chamber cover and gasket.
15. Remove valve hold down plates and valves.
16. If water jacket needs to be cleaned, remove side cover and bottom plate and gaskets.

KDH-130B & 150 REASSEMBLY (See pages 16 & 17)

Before reassembling pump, clean and de-burr all mating surfaces. Apply a thin film of oil on all internal parts and inside of cylinder bores as parts are reassembled. When looking at the OE of the cylinder, the suction flange is to the left side.

1. Replace bearings in both heads.
2. Replace valves and valve hold down plates using new bolts with self-locking nylon.
3. Attach valve chamber cover and gasket.
4. Attach CE head on dowel pins without using sealer using 4 bolts.
5. If OE cam was removed, replace keys if needed and press OE cam onto shaft with the two threaded puller holes facing outward. The OE cam is the heavier of the two cams.
6. Insert the shaft and cam into cylinder until the CE head end of the shaft is into the CE head bearing and the cam is up against the center wall.
7. Put the slide pin onto the tang of the piston. The wider two of the long edges of the slide pin go towards the piston.
8. With the slots in the piston tang facing down, put the slide pin and piston onto the OE cam.
9. Clean and apply Loctite 515 to OE head and cylinder.
10. Attach OE head to cylinder. Tighten middle bolts first and work outwards.
11. Rotate shaft counter clockwise a few times. If it will not rotate completely around, remove OE head to check that slide pin is on the piston tang properly and that there is not any foreign material inside that would stop piston from rotating.
12. Remove CE head.
13. Replace keys if needed and tap CE cam onto shaft with the two threaded puller holes facing outward.
14. Replace the piston and slide pin as in steps #7 and #8.
15. Attach CE head as in steps #9 and #10.
16. Rotate shaft as in step #11
17. Attach CE cap with o-ring to CE head.
18. Lubricate o-ring on seal seat and insert seal seat into shaft seal housing.
19. Replace retaining ring and carefully slide seal assembly onto shaft. Be sure there are no burrs on the shaft shoulder. Use vacuum grease or oil to lubricate shaft.
20. Attach shaft seal housing and o-ring to OE head.

21. Replace backup ring, bearing, locknut and bearing clamping plate.
22. Attach oil and gas ballast lines. Be sure lines and valves are clean and clear.
23. If removed, replace side cover and bottom plate and gaskets.

NOTES: To check the solenoid valve, run pump at blank-off. Note oil level in sight glass. Open the gas ballast valve; the oil level should rise. Close the gas ballast valve and the oil level should drop back to normal operating level. If the oil level does not change, it could be a faulty solenoid valve or clogged oil lines.

When replacing the shaft seal, the bearing and locknut should also be replaced.

REPLACEMENT PARTS

SPARE PARTS

A minimum quantity of spare parts can save costly and perhaps lengthy periods of breakdown. Tuthill Vacuum & Blower Systems offers different levels of maintenance kits for servicing of the pumps. Contact the factory at 1-800-825-6937 with the serial number for more information.

ORDERING PARTS

Each pump has a nameplate attached to the cylinder on the lower left corner facing the closed head. When ordering parts, it is important that the correct model designation and serial number, as listed on the nameplate, be included along with the reference number and description of each part ordered. Parts should be ordered through your nearest Tuthill Vacuum & Blower distributor.

NOTES: _____

KDH-130B & 150 FINAL ASSEMBLY

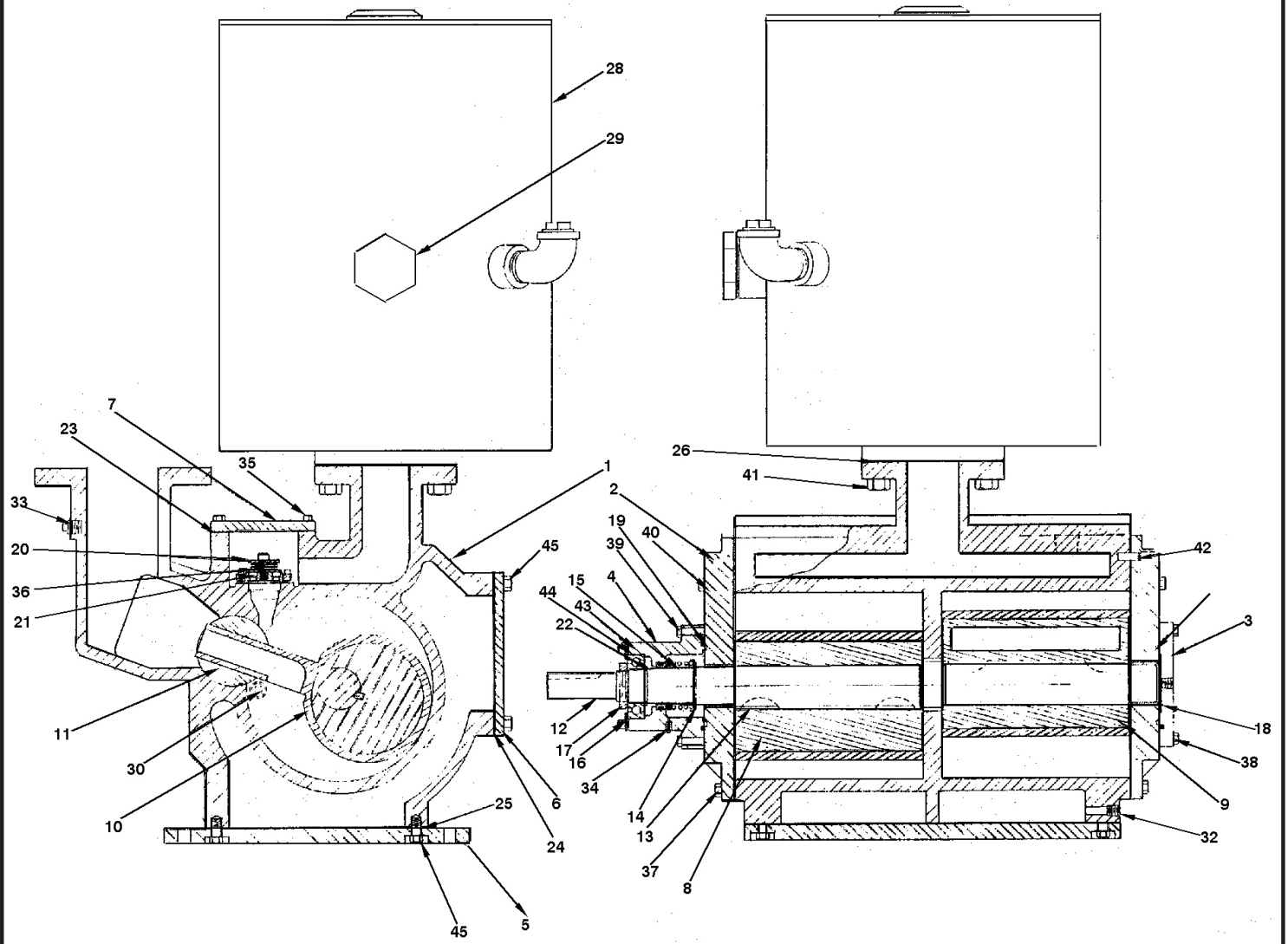

KDH-130B & 150 FINAL ASSEMBLY

ITEM #	DESCRIPTION	PART NUMBER	QTY
1	CYLINDER	808556 D000	1
2	HEAD, OE & CE	808554 D000	2
3	CAP, CLOSED END	808563 B000	1
4	HOUSING, SS & BRG	808557 B000	1
5	BOTTOM PLATE	808568 B000	1
6	SIDE COVER	808567 A000	1
7	COVER, VLV CHMBR	807051 B000	1
8	CAM, OE	801324 B000	1
9	CAM, CE	801325 B000	1
10	PISTON	801322 B000	2
11	SLIDEPIN	807401 B000	2
12	SHAFT	808558 B000	1
13	KEY, WDF 29	064060 00ST	4
14	RINGRTING1.50EXT	064006 00ST	1
15	SS,BUNA-N, 1-1/2	065067 A000	1
16	BALL BEARING 1207-FF35X72X17	054159 0000	1
17	BEARING LOCKNUT N-07	054160 0000	1
18	BEARING SLEEVE, BRONZE	808615 A000	2
19	O-RING2-238U-N	050238 0VIT	2
20	DV ASSY K 1-1/2	066161 A000	4
21	HLDN PLATE, DISCH VLV	808624 A000	2
22	BACK-UP RING, BEARING	808744 A000	1
23	GSKT, CHMBR COVR	806465 A000	1
24	GASKER, SIDE COVER	808569 A000	1
25	GASKET, BOTTOM PLATE	808570 B000	1
26	GSKT, INLET FLG	807057 A000	1
28	SEPARATOR TANK	806229 A000	1
29	OIL SG 2" NPT	060010 0000	1
30	PPG, HEXS 3/8	057363 00ST	2
31	PPG, SQH 3/8 (not shown)		1
32	PPG,SQH 3/8	057018 00BR	1
33	PPG.SQH 1/4	057004 00ST	1
34	PPG. SQH 1/8	057001 00ST	1
35	HHCS 3/8-16-1	052271 0STZ	10
36	SHCS 5/16-18-7/8	052469 STNY	12
37	HHCS 5/16-18-7/8	052456 0STZ	18
38	HHCS 5/16-18-1	052246 0STZ	4
39	HHCS 5/16-18-6/4	052251 0STZ	4
40	HHCS 5/16-18-7/4	052112 0STZ	8
41	HHCS 5/8-11-5/4	052302 0STZ	4
42	DWLPIN 3/4X7/8	053073 00ST	4
43	CLAMPING PLATE	808749 A000	1
44	SHCS 1/4-20-5/8	052076 00ST	4
45	HHCS 5/16-18 X 7/8	052602 0AST	32

WARRANTY – VACUUM PRODUCTS

Subject to the terms and conditions hereinafter set forth and set forth in General Terms of Sale, Tuthill Vacuum & Blower Systems (the Seller) warrants products and parts of its manufacture, when shipped, and its work (including installation and start-up) when performed, will be of good quality and will be free from defects in material and workmanship. This warranty applies only to Seller's equipment, under use and service in accordance with Seller's written instructions, recommendations and ratings for installation, operating, maintenance and service of products, for a period as stated in the table below. Because of varying conditions of installation and operation, all guarantees of performance are subject to plus or minus 5% variation. (Non-standard materials are subject to a plus or minus 10% variation).

PRODUCT TYPE	WARRANTY DURATION
New	15 months after date of shipment or 12 months after initial startup date, whichever occurs first
Piston Pumps	30 months after date of shipment, on all units sold after June 1, 2014.
Repair	6 months after date of shipment or remaining warranty period, whichever is greater
Remanufactured	9 months after date of shipment or 6 months after initial startup date, whichever occurs first

THIS WARRANTY EXTENDS ONLY TO BUYER AND/OR ORIGINAL END USER, AND IN NO EVENT SHALL THE SELLER BE LIABLE FOR PROPERTY DAMAGE SUSTAINED BY A PERSON DESIGNATED BY THE LAW OF ANY JURISDICTION AS A THIRD PARTY BENEFICIARY OF THIS WARRANTY OR ANY OTHER WARRANTY HELD TO SURVIVE SELLER'S DISCLAIMER.

All accessories furnished by Seller but manufactured by others bear only that manufacturer's standard warranty.

All claims for defective products, parts, or work under this warranty must be made in writing immediately upon discovery and, in any event within one (1) year from date of shipment of the applicable item and all claims for defective work must be made in writing immediately upon discovery and in any event within one (1) year from date of completion thereof by Seller. Unless done with prior written consent of Seller, any repairs, alterations or disassembly of Seller's equipment shall void warranty. Installation and transportation costs are not included and defective items must be held for Seller's inspection and returned to Seller's Ex-works point upon request.

THERE ARE NO WARRANTIES, EXPRESSED, IMPLIED OR STATUTORY WHICH EXTEND BEYOND THE DESCRIPTION ON THE FACE HEREOF, INCLUDING WITHOUT LIMITATION, THE IMPLIED WARRANTIES OF MERCHANTABILITY AND FITNESS OF PURPOSE.

After Buyer's submission of a claim as provided above and its approval, Seller shall at its option either repair or replace its product, part, or work at the original Ex-works point of shipment, or refund an equitable portion of the purchase price.

The products and parts sold hereunder are not warranted for operation with erosive or corrosive material or those which may lead to build up of material within the product supplied, nor those which are incompatible with the materials of construction. The Buyer shall have no claim whatsoever and no product or part shall be deemed to be defective by reason of failure to resist erosive or corrosive action nor for problems resulting from build-up of material within the unit nor for problems due to incompatibility with the materials of construction.

Any improper use, operation beyond capacity, substitution of parts not approved by Seller, or any alteration or repair by others in such manner as in Seller's judgment affects the product materially and adversely shall void this warranty.

No employee or representative of Seller other than an Officer of the Company is authorized to change this warranty in any way or grant any other warranty. Any such change by an Officer of the Company must be in writing.

The foregoing is Seller's only obligation and Buyer's only remedy for breach of warranty, and except for gross negligence, willful misconduct and remedies permitted under the General Terms of Sale in the sections on CONTRACT PERFORMANCE, INSPECTION AND ACCEPTANCE and the PATENTS Clause hereof, the foregoing is BUYER'S ONLY REMEDY HEREUNDER BY WAY OF BREACH OF CONTRACT, TORT OR OTHERWISE, WITHOUT REGARD TO WHETHER ANY DEFECT WAS DISCOVERED OR LATENT AT THE TIME OF DELIVERY OF THE PRODUCT OR WORK. In no event shall Buyer be entitled to incidental or consequential damages. Any action for breach of this agreement must commence within one (1) year after the cause of action has occurred.

June 2014

OPERATING DATA FORM / PRODUCT REGISTRATION

It is to the user's advantage to have the requested data filled in below and available in the event a problem should develop in the blower or the system. This information is also helpful when ordering spare parts.

Model No.	_____	V-Belt Size	_____	Length	_____
Serial No.	_____	Type of Lubrication	_____		
Startup Date	_____	_____			
Pump RPM	_____	Operating Vacuum	_____		
Pump Sheave Diameter	_____	Any other Special Accessories Supplied or in use:			
Motor Sheave Diameter	_____	_____			
Motor RPM	_____	HP	_____		

NOTES:

IMPORTANT

All blowers manufactured by Tuthill Vacuum & Blower Systems are date coded at time of shipment. In order to assure you of the full benefits of the product warranty, please complete, tear out and return the product registration card, or register online at tuthillvacuumblower.com.



**For Service & Repair, Technical Support,
or Product Sales contact:**

Tuthill Vacuum & Blower Systems

4840 West Kearney Street

Springfield, Missouri USA 65803-8702

O 417.865.8715 800.825.6937 F 417.865.2950

tuthillvacuumblower.com



Manual 1817 Rev A p/n 001817 0000